



40G LR4 DUAL PORT FIBER BYPASS MODULE

Product Description

The 1300nm 40G Dual QSFP+ LR4 quad port bypass module is designed as alternative 40Gbps dual QSFP+ LR4 transceiver. Its innovated design able the fiber bypass function become selectable within single PCI card. The 1300nm 40G Dual QSFP+ LR4 quad port bypass module is design expressly for Intrusion Prevention System (IPS) provides complete visibility to network traffic, It also introduces a point of failure should the IPS lose power, cable fail or application freeze.

This interconnecting system include dual ways transceivers offers 4 channels and maximum bandwidth of 40Gbps. It integrates four data lanes in each direction with 40 Gbps aggregate bandwidth. Each lane can operate at 10.3125 Gbps up to 10Km using Single Mode fiber(SMF). The optical interface uses a Dual-LC connector.



Features

- Compliant with 40G Ethernet
- IEEE 802.3ba 40GBASE-LR4 standards
- Compliant with SFF-8436 QSFP+ specification Revision 3.5
- Unretimed XLPPI electrical interface
- Utilizes a standard optical fiber with Dual-LC optical connector
- Link up to 10Km using Single Mode Fiber (SMF).
- Laser Class 1 Product with comply with Requirements of IEC 60825-1 and IEC 60825-2

Applications

- 40GbE and 40G-IB-QDR / 20G-IB-DDR / 10G-IB-SDR interconnects
- Client-side 40G Telecom connections
- 4G/8G/10G fiber Channel
- STTA/SAS Storage
- In-Line Security
- Web Acceleration Appliances

40G Dual QSFP+ LR Dual Port Bypass Module – Optical Path

Bypass Mode Between 40G Segment 1 and 40G Segment 2

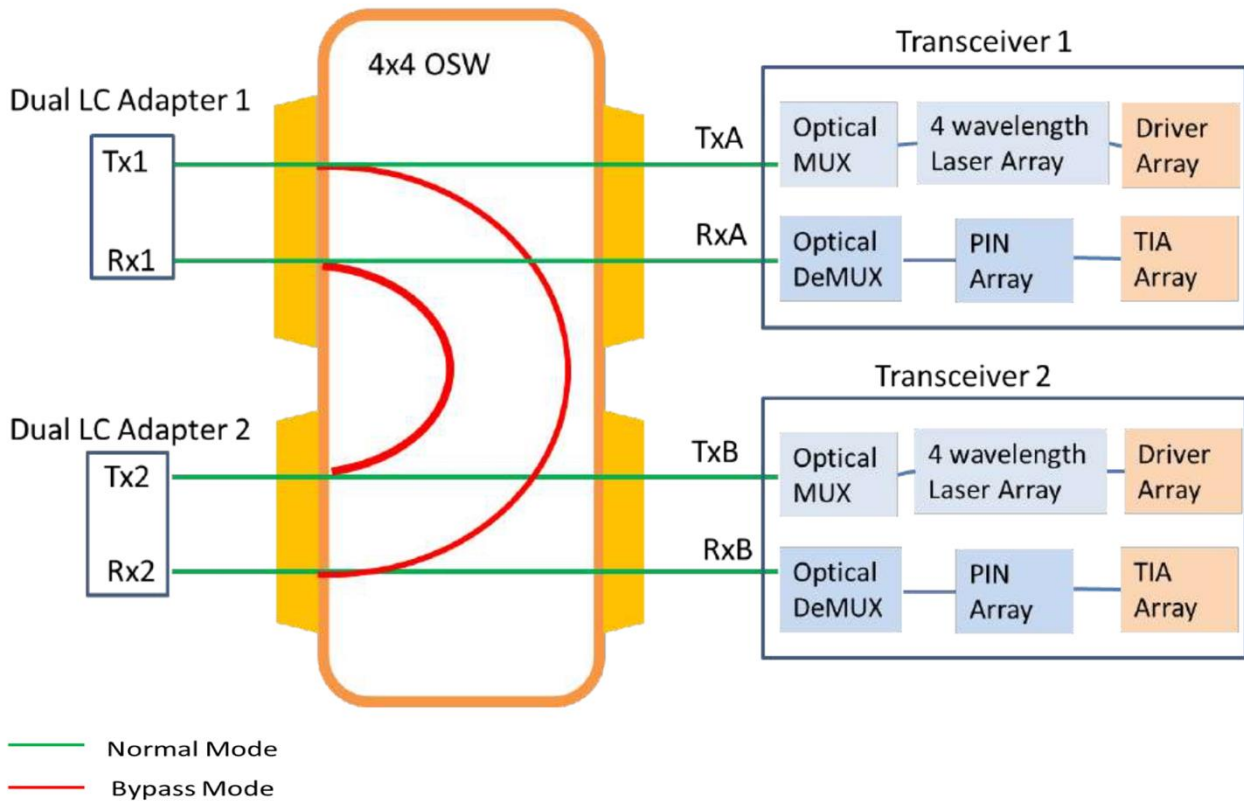

Absolute Maximum Ratings

Parameter	Symbol	Min.	Typ.	Max.	Unit	Note
Storage Temperature	Ts	-40		85	°C	
3.3V Supply Voltage	Vcc3(3.3V)	-0.5		3.6	V	Vcc3(3.3V)
Relative Humidity	—	5		85	%	2
Data Input Voltage — Single Endes		-0.5		Vcc+0.5	V	
Transceiver Rx damage Threshold / Lane	DT	3.4			dBm	

Recommended Operating Conditions

Parameter	Symbol	Min.	Typ.	Max.	Unit	Note
Case Operation Temperature	Ts	0	40	70	°C	1
3.3V Supply Voltage	Vcc(3.3V)	3.14	3.3	3.46	V	Vcc (3.3V)
3.3V Supply Current	Icc		1420	1500	mA	Icc (Total)
Data Rate per Channel	bps		10.3125		Gbps	

Note :

1. Consuming Temperature
2. Non Condensation



Electrical Characteristics

Parameter	Symbol	Min.	Typ.	Max.	Unit	Note
3.3V Supply Voltage (Include Vcc1, Vcc2, VccTX1, VccTR2 VccRx1, VccRx2)	Vcc3(3.3V)	3.14	3.3	3.46	V	
Data Rate per Channel	bps		10.3125		Gbps	
Control Input Voltage High	V _{IH}	2.4		V _{cc} +0.3	V	
Control Input Voltage Low	V _{IL}	-0.3		0.8	V	
Two Wire serial(TWS) Interface Clock Rate				400	KHz	
Transmitter Differential input Impedance	Z _d		100		Ω	1
Receiver Differential Output Impedance	Z _d		100		Ω	2
Link distance on OM2 MMF		0.5		30	m	
Link distance on OM3 MMF		0.5		100	m	
Link distance on OM4 MMF		0.5		150	m	
Transmitter						
TRx Power-On Initiation Time				2000	mS	3
Data Differential Input Voltage Swing	V _{DIFF}	200		1200	mV	1
Differential Input Voltage	V _{DT}	0.5		2.4	V	1
Differential Input Return Loss	Per IEEE 802.3ba Section 86A.4.1.1				dB	5
Differential to Command Mode Input Return Loss		10			dB	5
J2 Jitter Tolerance	Jt2	0.17			UI	
J9 Jitter Tolerance	Jt9	0.29			UI	
Eye Mask Coordinate : X1, X2; Y1, Y2	Specification Value : 0.11, 0.31; 95,350				UI;mV	
Receiver						
Data Differential Output Voltage Swing	V _{DIFF}	200		900	mV	2
Output Transition Time 20% to 80%	Tr, Tf	28			pS	
Differential Output Return Loss	Per IEEE 802.3ba Section 86A.4.2.1				dB	5
Differential to Command Mode Output Return Loss	Per IEEE 802.3ba Section 86A.4.2.2				dB	5
J2 Jitter Output	Jo2			0.42	UI	
J9 Jitter Output	Jo9			0.95	UI	
Eye Mask Coordinate : X1, X2; Y1, Y2	Specification Value : 0.29, 0.5; 150, 425				UI;mV	
Optical Bypass Switch						
Optical Switch Supply Voltage	Vcc5(5V)	4.5	5.0	5.5	V	3.3V to 5V
Operation Current (Total)	I _{SW}			240	mA	
Latching Voltage-High	V _{LATH}	4.5	5.0	5.5	V	
Latching Voltage-Low	V _{LATL}	0		0.8	V	
Latching Resistance	R _{LAT}		125		Ω	±10%
Switching Time (Input Pulse ≥ 20ms)	t _{ST}			5.0	msec	

Note :

1. Internally AC couples and terminated to 100-Ohms differential load.
2. Internally AC coupled, but requires a 100-Ohms differential termination at or internal to Serializer/Deserializer.
3. "Initialization Time" is the time from when the supply voltage hot swap time reach and remain above the minimum "Recommended Operating Conditions" to the time when the module enables TWS access. The module at that point is fully functional.
4. 10M to 11.1 GHz according to IEEE 802.3ba specification.
5. Hit ratio= 5×10^{-5} per sample.

Optical Characteristics

Parameter	Symbol	Min.	Typ.	Max.	Unit	Note
Transmitter						
Lane center Wavelengths(range)	λ_c			1264.5-1277.5 1284.5-1297.5 1304.5-1317.5 1324.5-1337.5	nm	
Total Average Launch Power	P_{out}			8.3	dBm	
Average Launch Power, each lane	TXPx	-7.0		2.3	dBm	1,6
Optical Extinction Ratio	ER	3.5			dB	
Output Optical Modulation Amplitude,per lane	TxOMA	-4.0		3.5	dBm	1,8
Difference in Power between any Two Lanes in OMA				6.5	dB	1
Transmitter and Dispersion Penalty,each lane	TDP			3.5	dB	
Relative Intensity Noise	RIN			-128	dB/Hz	7
Disable Output Optical Power	P_{O-OFF}			-30	dB	
Sidemode Suppression Ratio	SSRmin	30			dB	
Optical Return Loss Tolerance				20	dB	
Transmitter Reflectance	R_t			-12	dB	
Eye Mask Coordinate : X1, X2, X3; Y1, Y2, Y3		Specification Value : 0.25, 0.4, 0.45; 0.25, 0.28, 0.4			UI	2
Receiver						
Center Wavelength, each lane	λ_c			1264.5-1277.5 1284.5-1297.5 1304.5-1317.5 1324.5-1337.5	nm	
Damage threshold				3.4	dBm	
Average Receiver Power, each lane	P_{in}	-11.5		2.3	dBm	3
Stressed Sensitivity (OMA)				-9.6	dBm	3
Receiver Sensitivity (OMA),each lane				-11.5	dBm	



LOS Assert	P_A	-28			dBm	
LOS De-Assert	P_D			-15	dBm	
LOS Hysteresis			1		dB	
Total Average Receiver Power	P_{in}			8.3	dBm	
Receiver Power (OMA) per Lane				3.5	dBm	
Return Loss				-26	dB	
Vertical eye closure penalty, per lane				1.9	dB	
Receive electrical 3 dB upper cutoff frequency, per lane				12.3	GHz	
Optical Bypass Switch						
Center Wavelength	λ_c	1260		1335	nm	
Insertion Loss (Normal Mode)	IRL	-4.0		0	dB	4
Insertion Loss (Bypass Mode)	IRL	-4.0		0	dB	5
Return Loss (Bypass Mode)	ORL	50			dB	

Note :

1. Output power is power couples into a 9/125um Single-mode fiber (SMF).
2. Hit ratio= 5×10^{-5} per sample.
3. Measured with 10.3125Gbps of PRBS-31 at 10-12 BER.
4. Normal Mode (Bypass Mode Off).
5. Bypass Mode (Normal Mode Off).
6. Minimum value is informative.
7. RIN is scaled by $10 \cdot \log(10/4)$ to maintain SNR outside of transmitter.
8. Minimum value is informative, equals min TxOMA with infinite ER and max channel insertion loss.