



1.25GBPS LX/LH QUAD PORT FIBER DUAL BYPASS MODULE

Product Description

The LX/LH Quad port fiber dual bypass modules is design expressly for Intrusion Prevention System (IPS) provides complete visibility to network traffic, It also introduces a point of failure should the IPS lose power, cable fail or application freeze. The module design for PCI Express X8 interface, which means it can support 1.25Gbit/s in full duplex mode per port of data transfer rate and Single-mode fiber operations. LX/LH Quad port fiber dual bypass modules designed to be compliant digital diagnostic monitoring function: Temperature, VCC, TX optical power, TX laser bias current, and RX received optical power. The post-amplifier of the LX/LH Quad port fiber dual bypass module also includes a Loss of Signal (LOS) circuit that provides a TTL logic-high output when the received optical level is below a preset LOS Assert threshold.



Features

- Compliant with 10GBASE-LR
- Compliant with 10GBASE-LW
- Link Distances at 1.25Gbps 10Km links with 9/125um Single Mode Fiber Cable
- EEPROM with Series ID Function
- Quad LC Connector interface with optical Bypass Function
- Laser Class 1 Product with comply with Requirements of IEC 60825-1 and IEC 60825-2
- LED indicate operation function

Applications

- In-Line traffic Monitoring, Analyzing and Optimization
- Intrusion Prevention System
- Quality of Service
- In-Line Security
- Load balance
- Web Acceleration Appliances

LASER SAFETY

This Single-mode Quad Port Fiber Bypass Module is a Class 1 laser product. It complies with IEC 60825 and FDA 21 CFR 1040.10 and 1040.11. The module must be operated within the specified temperature and voltage limits. The optical port of the module shall be terminated with an optical connector or with a dust plug.



LX/LH Quad Port Bypass Module – Optical Path Portion

Quad Port Dual Bypass Path is 1<->4 & 2<->3

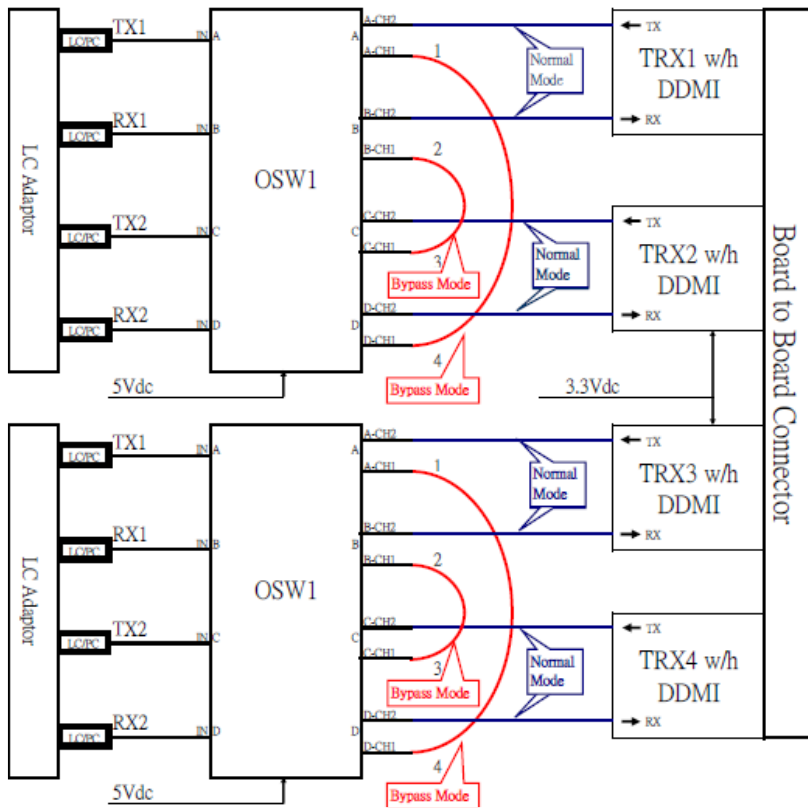

Absolute Maximum Ratings

Parameter	Symbol	Min.	Typ.	Max.	Unit	Note
Storage Temperature	Ts	-40		85	°C	
Supply Voltage	Vcc	0		5	V	

Recommended Operating Conditions

Parameter	Symbol	Min.	Typ.	Max.	Unit	Note
Case Operation Temperature	Ts	-5		70	°C	1
+5V Supply Voltage	Vcc5	4.75		5.25	V	Vcc5,6
+3.3V Supply Voltage	Vcc3	3.135		3.465	V	Vcc1,2,3,4
+5V Supply Current	Icc5		150	300	mA	Icc5,6
+3.3V Supply Current	Icc3			1200	mA	Icc1,2,3,4
Relative Humidity	—	5		85	%	2

Note :

1. Consuming Temperature
2. Non Condensation



Electrical Characteristics

Parameter	Symbol	Min.	Typ.	Max.	Unit	Note
Transmitter						
Differential Input Impedance	Z _d		100		Ω	1
Differential Input Voltage Swing	V _{DIFF}	180		700	mV	1
Differential Input Voltage	V _{DT}	0.5		2.4	V	1
Disable Input-High	V _{DISH}	2.4		V _{cc} +0.3	V	
Disable Input-Low	V _{DISL}	0		0.8	V	
Fault Pull Up Resistor	R _{TX_FAULT}	4.7		10	KΩ	2
Fault Output-High	V _{TXFH}	2.4		V _{cc}	V	2
Fault Output-Low	V _{TXFL}	0		0.5	V	2
TX_DISABLE Asserted Time	t _{OFF}			10	μsec	
TX_DISABLE Deasserted Time	t _{ON}			1	msec	
Time to initialize, include reset of TX_FAULT	t _{init}			300	msec	
TX_FAULT from fault to assertion	t _{fault}			100	μsec	
TX_DISABLE time to reset	t _{reset}	10			μsec	
Receiver						
Differential Output Impedance	Z _d		100		Ω	1
Differential Output Voltage	V _{DR}	0.35		0.85	V	3
LOS Load Resistor	R _{RX_LOS}	4.7		10	KΩ	2
LOS Output Voltage-High	V _{LOSH}	2.4		V _{cc}	V	2
LOS Output Voltage-Low	V _{LOSL}	0		0.5	V	2
LOS Asserted Time (Transmitter off to on)	t _{A,RX_LOS}			100	μsec	4
LOS Deasserted Time(Transmitter on to off)	t _{D..RX_LOS}			100	μsec	4
Optical Bypass Switch						
Operation Voltage	V _{SW}	4.5	5.0	5.5	V	
Operation Current	I _{SW}		80	100	mA	
Latching Voltage-High	V _{LATH}	4.5	5.0	5.5	V	
Latching Voltage-Low	V _{LATL}	0		0.8	V	
Latching Resistance	R _{LAT}		125		Ω	±10%
Switching Time (Input Pulse ≥20ms)	t _{ST}			5.0	msec	
Timing						
Series ID Clock Rate	F _{serial_clock}			100	KHz	DDMI function

Note :

1. Internally AC couples and terminated to 100-Ohms differential load.
2. Pull up to V_{cc} on Host-Board.
3. Internally AC coupled, but requires a 100-Ohms differential termination at or internal to Serializer/Deserializer.
4. These are 20%~80% values.



Optical Characteristics

Parameter	Symbol	Min.	Typ.	Max.	Unit	Note
Transmitter						
Output Optical Power (AVG.)	P _{OUT}	-6		-1	dBm	1 (9/125um)
Extinction Ratio	ER	9				1 (9/125um)
Center Wavelength	λ _C	1280	1310	1355	nm	
Spectral Width	Δλ			2.5	nm	RMS(σ)
Optical Rise Time (20% to 80% values)	t _r			260	ps	
Optical Fall Time (20% to 80% values)	t _f			260	ps	
Total Jitter	TJ			227	ps	
Relative Intensity Noise	RIN			-120	dB/Hz	
Output Eye	Compliant with IEEE802.3z					
Max. Pout TX-DISABLE Asserted	P _{OFF}			-45	dB	
Receiver						
Optical Input Power (Over Load)	P _{MAX}	-3			dBm	2 (9/125um)
Receiver Sensitivity (AVG.) (BER<10E-12 and PRBS=2 ⁷ -1)	P _{IN1}		-26	-21	dBm	2 (9/125um)
Center Wavelength	λ _C	1260		1610	nm	
Optical Return Loss	ORL			-12	dB	
LOS Asserted (AVG.)	P _A			-22	dBm	
LOS De-asserted (AVG.)	P _D	-35			dBm	
LOS Hysteresis	P _A -P _D	0.5		3.0	dB	
Optical Bypass Switch						
Center Wavelength	λ _C	1260		1560	nm	
Insertion Loss (Bypass Mode)	IRL	2.0		4.0	dB	3 (9/125um)
Return Loss (Bypass Mode)	ORL			-50	dB	2 (9/125um)

Note :

1. Output power is power couples into a 9/125um single-mode fiber.
2. Normal Mode (Bypass Mode Off).
3. Bypass Mode (Normal Mode Off).