

2X4 BYPASS OPTICAL SWITCH

Product Description

Lightwave Link Inc. 2x4 Bypass optical switch with R15 Corning® ClearCurve® XB or equivalent Optical Fiber is designed for use in optical fiber communication networks and measurement instruments. The switch consists of two ports that selectively transmits, redirects, or blocks optical power in a fiber optic transmission line. The optical switch must be actuated to select or change between two states. Furthermore, for the Latching type, it only takes an electrical pulse width with duration $\geq 20\text{msec}$ to change the state. As a result, it consumes low electric energy to operate the optical switch. Lightwave Link Inc. 2x4 Bypass optical switch fully complies with RoHS Directive 2002/95/EC (2008/385/EC).

Features

- Smallest Size
- Low Insertion-Loss
- Fast Switching Speed
- PCB Mountable
- Available in Single Mode / Multi Mode
- RoHS Compliance

Applications

- Optical network protection and restoration
- Optical network monitoring
- Reconfigurable add/drop multiplexers
- Transmission equipment protection
- Research and development
- Wavelength router

Performance Specification

Parameter	9µm Core Single Mode			50µm or 62.5µm Core Multi Mode			Unit
	Min.	Typ.	Max.	Min.	Typ.	Max.	
Wavelength Range ¹	1260~1630			850/1300			nm
Straight Insertion Loss ²			1.0			0.5	dB
Bypass Insertion Loss ²			2.0			1.0	dB
Return Loss	-50						dB
PDL			0.1				d
WDL			0.3				dB
Crosstalk	-80			-80			dB
Repeatability			±0.1			±0.1	dB
Switching Time ³			3.5			3.5	ms
Absolute Optical Input Power			500			500	mW
Operating Current	Latching: 40±10% / Non-Latching: 28±10%						mA
Operating Voltage	4.5	5.0	5.5	4.5	5.0	5.5	VDC
Power Consumption	Latching: 200±10% / Non-Latching: 140±10%						mW
Switching Life Expectancy	3x10 ⁷			3x10 ⁷			Cycles
Operation Temperature-Normal	-5		70	-5		70	°C
Operation Temperature-Special	-20		70	-20		70	°C
Storage Temperature	-40		85	-40		85	°C
Operation Humidity	5		95	5		95	%RH
Storage Humidity	5		95	5		95	%RH
Dimension (H*W*L)	7.6 x 11 x 22.6						mm
Ring Size	Inner ring dimension ≥ 4						cm
Weight ⁴	10						g

1. Special wavelength would be upon request.
2. Optical parameters excluded connectors.
3. A minimum $\geq 20\text{ms}$ pulse is recommended for latching type of switch.
4. The product weight excluded optical connectors.

Function Diagram

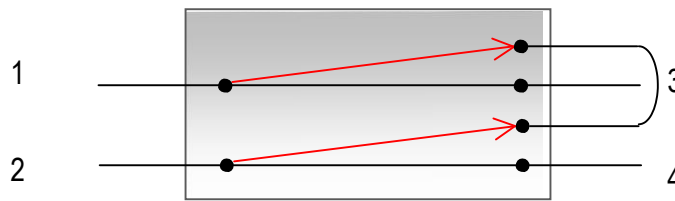

Physical Dimension

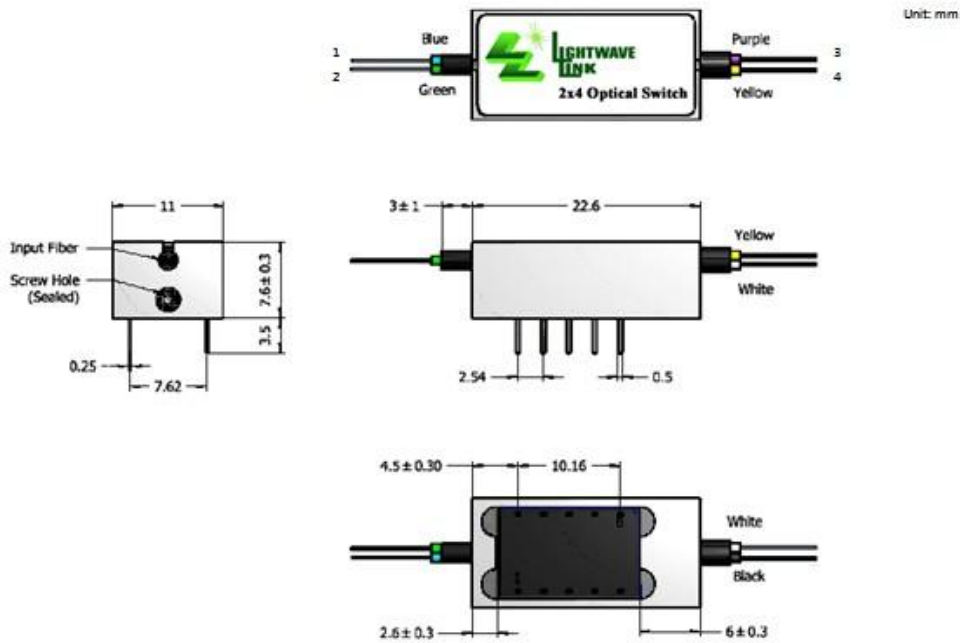



PIN Description

Pin Number	Latching Pin Function	Non-Latching Pin Function
1	Bypass activation terminal(+)	N/C
2	Straight Monitor	Straight Monitor
3	Monitor Common	Monitor Common
4	Bypass Monitor	Bypass Monitor
5	Bypass activation terminal(-)	Straight activation terminal(+)
6	Straight activation terminal(-)	Straight activation terminal(-)
7	Bypass Monitor	Bypass Monitor
8	Monitor Common	Monitor Common
9	Straight Monitor	Straight Monitor
10	Straight activation terminal(+)	N/C

Operation of the Optical Switch

Relay Type	PIN		1	5	6	10	PIN Connection	Remark
	OSW State							
Latching Type	1↔2		H	L	-	-	3, 4 pin closed ; 2, 3 pin open 7, 8 pin closed ; 8, 9 pin open	Bypass
	1↔3		-	-	L	H	2, 3 pin closed ; 3, 4 pin open 8, 9 pin closed ; 7, 8 pin open	Straight
	2↔4		-	-	L	H	2, 3 pin closed ; 3, 4 pin open 8, 9 pin closed ; 7, 8 pin open	Straight
Non-Latching Type	1↔2		-	-	-	-	3, 4 pin closed ; 2, 3 pin open 7, 8 pin closed ; 8, 9 pin open	Bypass (Default)
	1↔3		-	H	L	-	2, 3 pin closed ; 3, 4 pin open 8, 9 pin closed ; 7, 8 pin open	Straight
	2↔4		-	H	L	-	2, 3 pin closed ; 3, 4 pin open 8, 9 pin closed ; 7, 8 pin open	Straight

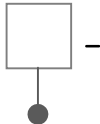
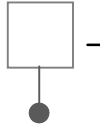
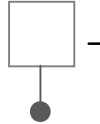
Ordering Information

Product Version	Input	Output	Operation Function	Fiber Type	Fiber Cabling	Connector Type
FOBWE ...	2 ...	4 ...				
	No. of Input	No. of Output	L: Latching N: Non-Latching	9: 9/125μm 50: 50/125μm 62: 62.5/125μm	B: Bare fiber L: 900μm loose tube	1: None 2: FC/PC 3: FC/APC 4: SC/APC 5: SC/PC 6: MU/PC 7: ST/PC 8: LC/PC 9: SC/UPC A: MT/RJ B: MU/UPC C: FC/UPC D: LC/APC E: LC/UPC

Application Circuitry for Latching Type

To provide sufficient power to switch, two application circuits using 2N2222 BJT and ULN2003 Darlington pair IC are showed below.

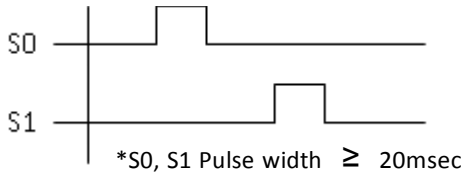
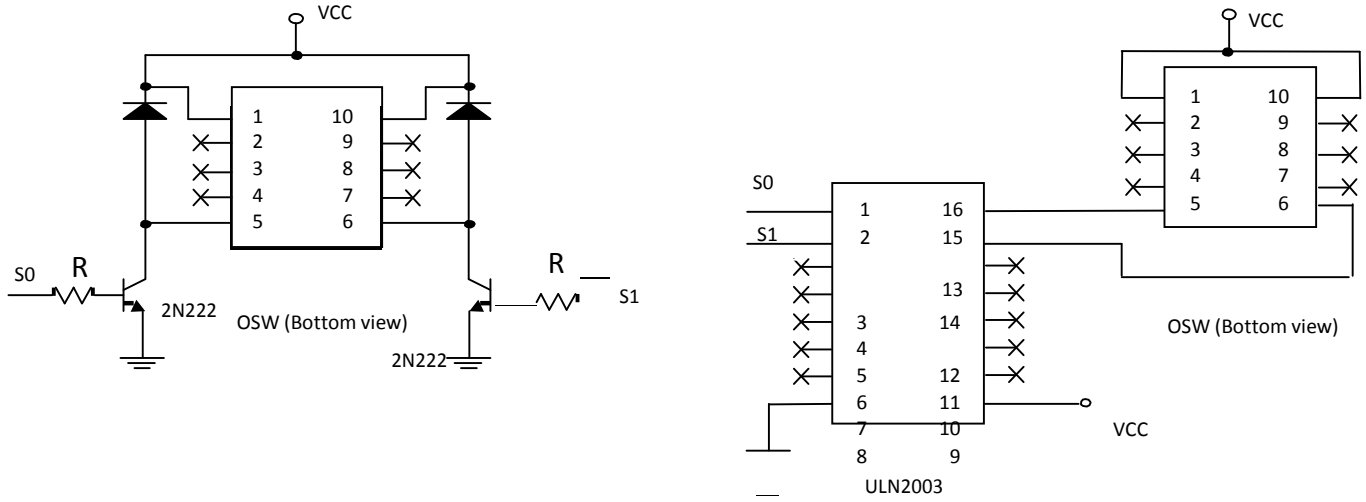

S0 = High, S1 = Low. To change the OSW state to ON state.
S0 = Low, S1 = High. To change the OSW state to OFF state.

The Recommend Circuitry for S0 and S1 Stand High Level Simultaneously

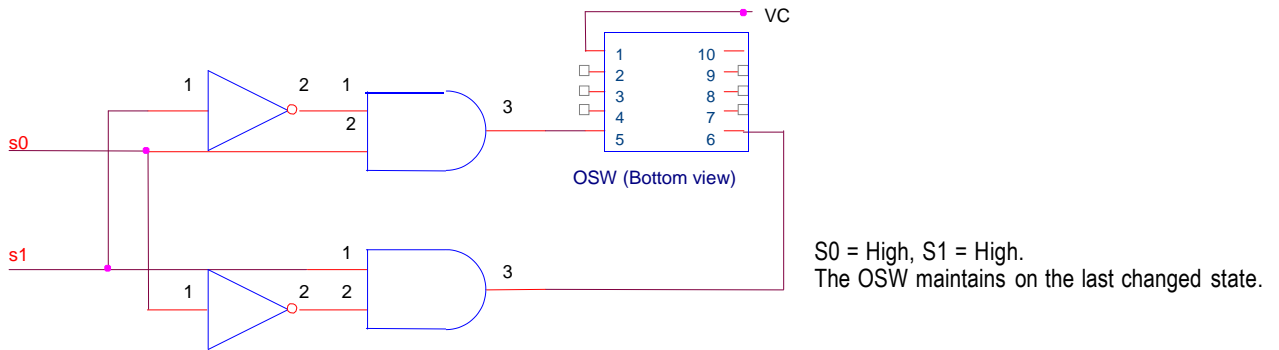

Application Circuitry for Non-Latching Type

To provide sufficient power to switch, two application circuits using 2N2222 BJT and ULN2003 Darlington pair IC are showed below.

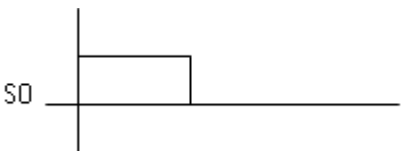
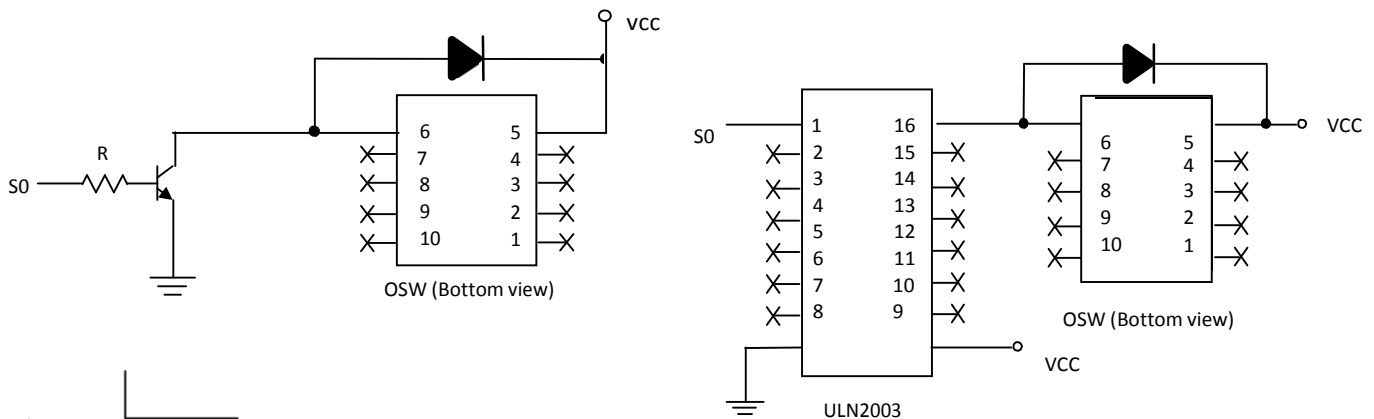

S0 = Low. To change the OSW state to default mode (Dual CH1).
S0 = High. To change the OSW state to Dual CH2.